

QT Series Model QT-10

Parts Manual
Record of Change 200

This manual contains important safety information and must be made available to all personnel who operate and/or maintain this product. Carefully read this manual before attempting to operate or perform maintenance on this compressor.

Fill Out & Return Warranty Registration Card Located Inside

Manual No. 50314-200

October 2008 Edition

TABLE OF CONTENTS

Recommended Spare Parts.....1
 Gasket Set.....1
 Overhauls Kit1
 Serial Number Identification.....2
 Ordering Replacement Parts.....2
 Quin-Cip Lubricant.....2
 Crankcase Lubricant Capacity.....2
 Crankshaft Group.....3
 Crankcase Group.....4
 Cylinder & Head Groups.....5-6
 Connecting Rod & Piston Groups7-8
 Control Piping Schematics.....9
 Pilot Valves.....10
 Pilot Valve Repair Kit.....10
 Differential Setting Charts10
 Suction Valve Unloader Assemblies..... 11
 Decals..... 11
 Typical Unit Repair Parts List.....12-13

This manual provides information for the Model QT-10 reciprocating compressor, per Record of Change 200.

The Model QT-10 is an aircooled, two stage, two cylinder, splash lubricated compressor, with up to 175 PSI continuous pressure capability. It has a 5" low pressure bore and a 2.75" high pressure bore, with a 3.5" stroke. This compressor can be run at 550-1000 RPM.

Available options include:

- head unloaders

CHANGES

Since previous printing dated April 2004:

The crankcase and cylinder were redesigned, and the high pressure piston was changed to cast iron.

INTRODUCTION

Recommended Spare Parts			
Item #	Qty.	Part Number	Description
	1	110377E100	air filter element
	1	114772	gasket set
	1	116162X	valve plate assembly, LP
	1	116163X	valve plate assembly, HP

Gasket Set 114772			
Item #	Qty.	Part Number	Description
	1	111781-001	oil seal
	1	111274-002	gasket, head to valve plate
	1	114585	gasket, cylinder to valve plate
	1	114586	gasket, head to valve plate
	1	114599	gasket, cylinder to valve plate
	1	114583	gasket, crankcase to brg. carrier
	1	114584	gasket, cylinder to crankcase
	3	112708-908	"o"ring, silicone

Overhaul Kit KQT10G			
Item #	Qty.	Part Number	Description
	1	116176	piston ring set, LP
	1	116177	piston ring set, HP
	1	114772	gasket set
	1	116163X	valve plate assembly, HP
	1	116162X	valve plate assembly, LP
	1	110377E100	air filter element
	1	110190-054	piston pin assembly, LP
	1	110190-055	piston pin assembly, HP
	2	114662K002	connecting rod assembly
	1	111333	breather filter

SERIAL NUMBER IDENTIFICATION

The unit serial number identification tag is located on the air tank top plate. The basic compressor serial number decal is located on the side of the crankcase opposite the oil fill side. *Fill in the numbers from your compressor unit and basic compressor in the corresponding spaces provided here, and reference this page when ordering replacement parts.*

Unit Serial Number <hr style="width: 80%; margin: 5px auto;"/>
Basic Serial Number <hr style="width: 80%; margin: 5px auto;"/>

All replacement parts are to be ordered through an authorized Quincy distributor. Insist on genuine Quincy parts only! Failure to do so may void warranty.

ORDERING REPLACEMENT PARTS

Prompt service can be rendered on repair parts orders if the following information is given:

- Item 1)** the model number, record of change number, & serial number.
- Item 2)** the exact part number needed. (Do not order by item numbers.)
- Item 3)** the exact quantity needed.
- Item 4)** the preferred type of transportation.

CRANKCASE LUBRICANT

Model	Capacity
QT-10	2.5 qts. (2.37 litres)

QUIN-CIP LUBRICANT

Refer to the chart below to order Quin-Cip-D or Quin-Cip compressor lubricant from your local authorized Quincy distributor.

Quin-Cip-D Lubricant (synthetic)	
SAE 30 (ISO 100)	
Quart	115468Q
Case (12 Qts.)	115468C
Quin-Cip Lubricant	
SAE 10W (ISO 32)	
Quart	112541Q032
Case (12 Qts.)	112541C032
SAE 20 (ISO 68)	
Quart	112542Q068
Case (12 Qts.)	112542C068
SAE 30 (ISO 100)	
Quart	112543Q100
Case (12 Qts.)	112543C100

CAUTION !
Refer to the QT Series instruction manual for vital lubrication information.

CAUTION !
Follow all safety precautions outlined in the QT Series instruction manual.

WARNING !
Do not operate this compressor without a totally enclosed belt guard or any other required safety equipment.

DANGER !
Air used for breathing or food processing must meet OSHA 1910.134 or FDA 21 CFR 178.3570 regulations. Failure to do so may cause severe injury or death.

CRANKSHAFT GROUP 116174

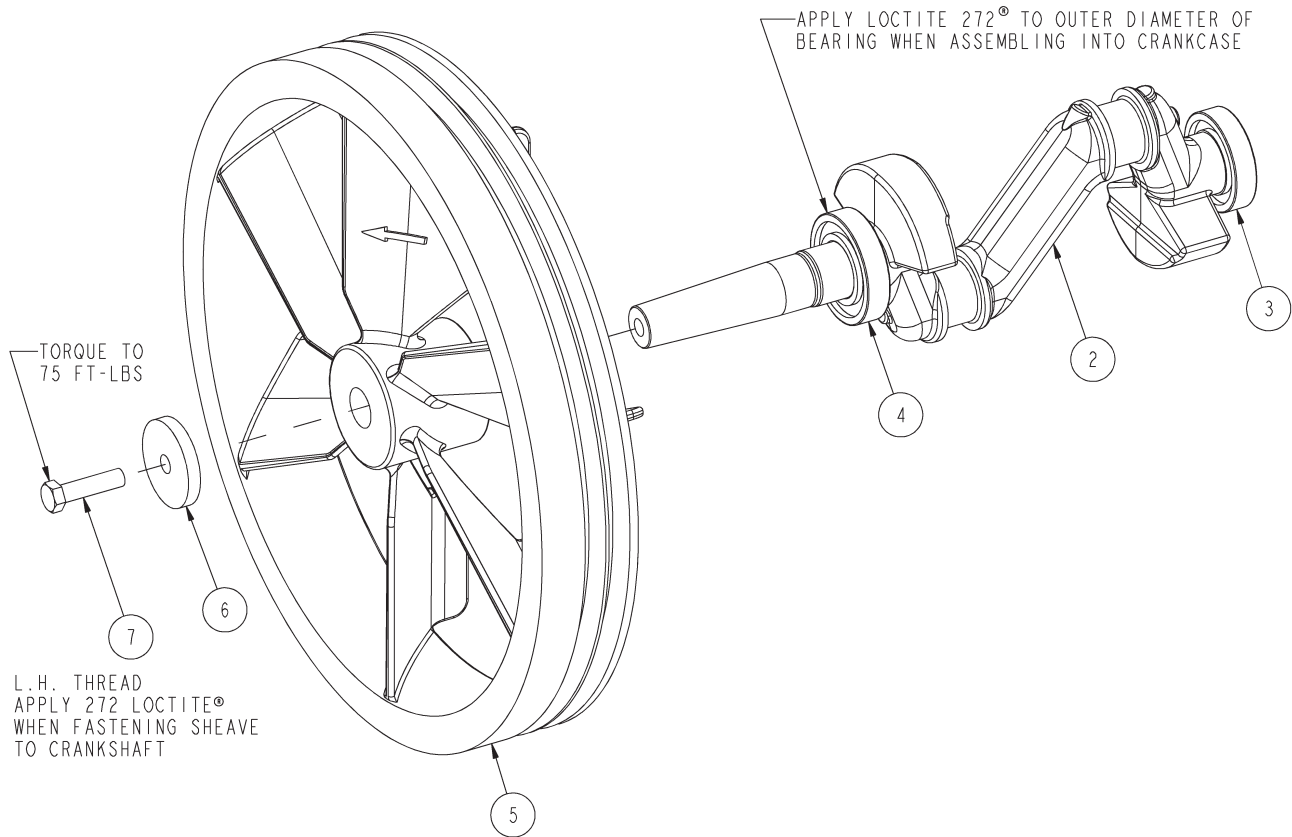

116174 CRANKSHAFT GROUP BILL OF MATERIALS			
ITEM	PART NUMBER	QTY	DESCRIPTION
1	116184X	1	GR, CRANKSHAFT (INCLUDES ITEM 2,3,4)
2	116184	1	CRANKSHAFT
3	111780	1	BALL BEARING
4	114571	1	BALL BEARING
5	111776-002	1	SHEAVE, 19.50 O.D., 2 GROOVE, B SECT. CCW
6	113077	1	WASHER
7	111128-N17	1	HEX SCREW, 1/2-20 UNF X 2.00, GRD 5, LH

CRANKCASE GROUP 116175

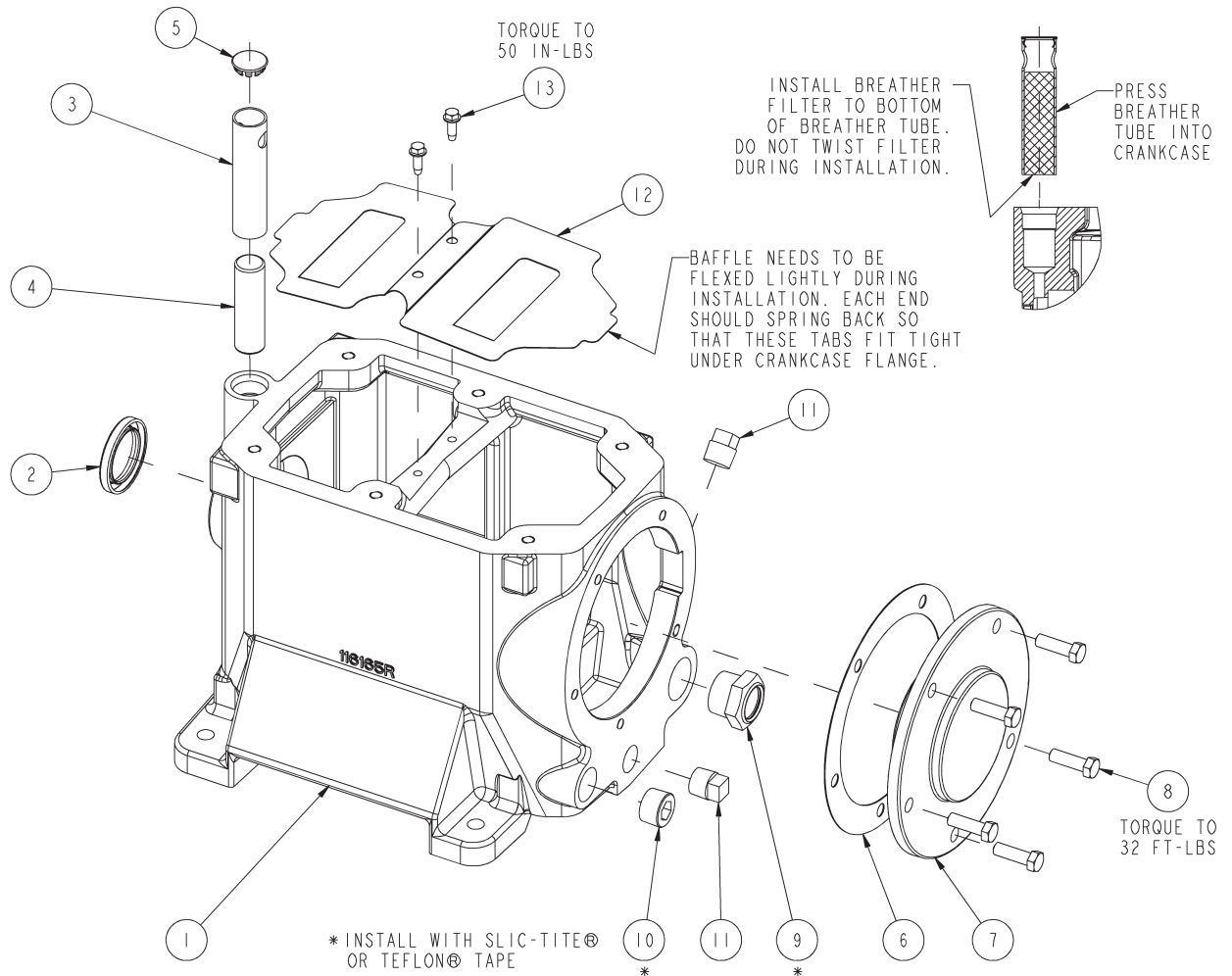

116175 CRANKCASE GROUP BILL OF MATERIALS			
ITEM	PART NUMBER	QTY	DESCRIPTION
1	116165	1	CRANKCASE
2	111781-001	1	OIL SEAL, VITON
3	113947	1	BREATHER TUBE
4	111333	1	FILTER
5	40825	1	HOLE PLUG
6	114583	1	GASKET, CARRIER
7	114567	1	CARRIER
8	115037-L14	5	SCREW, CAP HEX, SEALANT, GRADE 5
9	114177	1	OIL LEVEL SIGHT GAUGE, 1 NPT
10	2276	1	PIPE PLUG, 3/4 NPT
11	2057	2	PIPE PLUG
12	116179	1	CRANKCASE BAFFLE
13	110511-J10	2	TAPTITE SCREW, 1/4-20 UNC X .75

CYLINDER & HEAD GROUP 116178

(without head unloaders)

116178 HEAD AND CYLINDER GROUP, PLAIN BILL OF MATERIALS		DESCRIPTION
ITEM	PART NUMBER	QTY
1	116172	1 CYLINDER
2	114599	1 GASKET, CYLINDER/PLATE, HP
3	114585	1 GASKET, CYLINDER/PLATE, LP
4	116162X	1 VALVE PLATE ASSEMBLY, LP
5	116162-001	1 VALVE PLATE (N.S.S., ORDER V.P. ASSEMBLY)
6	112380	2 REED VALVE (N.S.S., ORDER V.P. ASSEMBLY)
7	112378-1	1 BUMPER (N.S.S., ORDER V.P. ASSEMBLY)
8	112728-112	4 FLATHEAD SCR, 1/4-20UNC X 1.00, GR 8
9	112359-2	2 REED VALVE (N.S.S., ORDER V.P. ASSEMBLY)
10	112379	1 BUMPER (N.S.S., ORDER V.P. ASSEMBLY)
11	112378-3	1 BUMPER (N.S.S., ORDER V.P. ASSEMBLY)
12	112379-1	1 BUMPER (N.S.S., ORDER V.P. ASSEMBLY)
13	112373-J02	4 HEX NUT, 1/4-20 UNC
14	114688	1 VALVE PLATE STUD
15	116163X	1 VALVE PLATE ASSEMBLY, HP
16	116163-001	1 VALVE PLATE (N.S.S., ORDER V.P. ASSEMBLY)
17	112380-001	2 REED VALVE (N.S.S., ORDER V.P. ASSEMBLY)
18	114645-002	1 BUMPER (N.S.S., ORDER V.P. ASSEMBLY)
19	114645-003	1 BUMPER (N.S.S., ORDER V.P. ASSEMBLY)
20	112728-112	2 FLATHEAD SCR, 1/4-20UNC X 1.00, GR 8
21	112373-J02	2 HEX NUT, 1/4-20 UNC
22	111274-002	1 GASKET, HEAD - VALVE PLATE
23	114586	1 GASKET, HEAD - VALVE PLATE
24	111115-6	1 HEAD, HIGH PRESSURE
25	114507	1 HEAD, LOW PRESSURE
26	114584	1 GASKET, CYLINDER - CRANKCASE
27	114595N038	8 FLAT WASHER, 3/8
28	109832L26	8 HEX. SCREW, 3/8-16 UNC X 4.50, GRADE 8
29	112709-006	3 PLUG, 3/4-16 UNF W/O RING
30	123651-003	1 PIPE ELBOW, 90° STREET, 1/4 NPT x 1/4 NPT
31	2961-100	1 PRESSURE RELIEF VALVE
32	115037-114	6 SCREW CAP HEX, SEALANT, GRADE 5
33	114595N025	1 FLAT WASHER, 1/4
34	112373-J02	1 HEX NUT, 1/4-20 UNC
35	141650-026	1 BRASS NIPPLE, 1 NPT X 4.00
36	115101-006	1 PIPE ELBOW, 1 NPT
37	23358	2 TUBE FITTING, MALE CONN. 1 X 1 NPT
38	21730-B	1 PIPE ELBOW, 90° STREET, 1 NPT x 1 NPT
39	114508-001	1 INTERCOOLER
40	114574	3 INTERCOOLER CLAMP
41	110428W038	3 FLAT WASHER, 3/8
42	123478-L10	2 HEX SCREW, 3/8-16 UNC X .75, GRADE 5
43	114629-001	1 FLANGE SCREW, 5/16-18x0.75, GRADE 5
MAINTENANCE PARTS		
	114508K002	1 INTERCOOLER REPLACEMENT KIT - INCLUDES INTERCOOLER AND NUT/SLEEVE FITTING
	112708-908	3 O-RING, SILICONE (SEE ITEM 29)
	K0110H	1 HEAD KIT (INCLUDES ITEMS 4, 15 & AIR FILTER ELEMENT)
	110377S125	1 AIR FILTER / SILENCER
	110377E100	1 ELEMENT, AIR FILTER

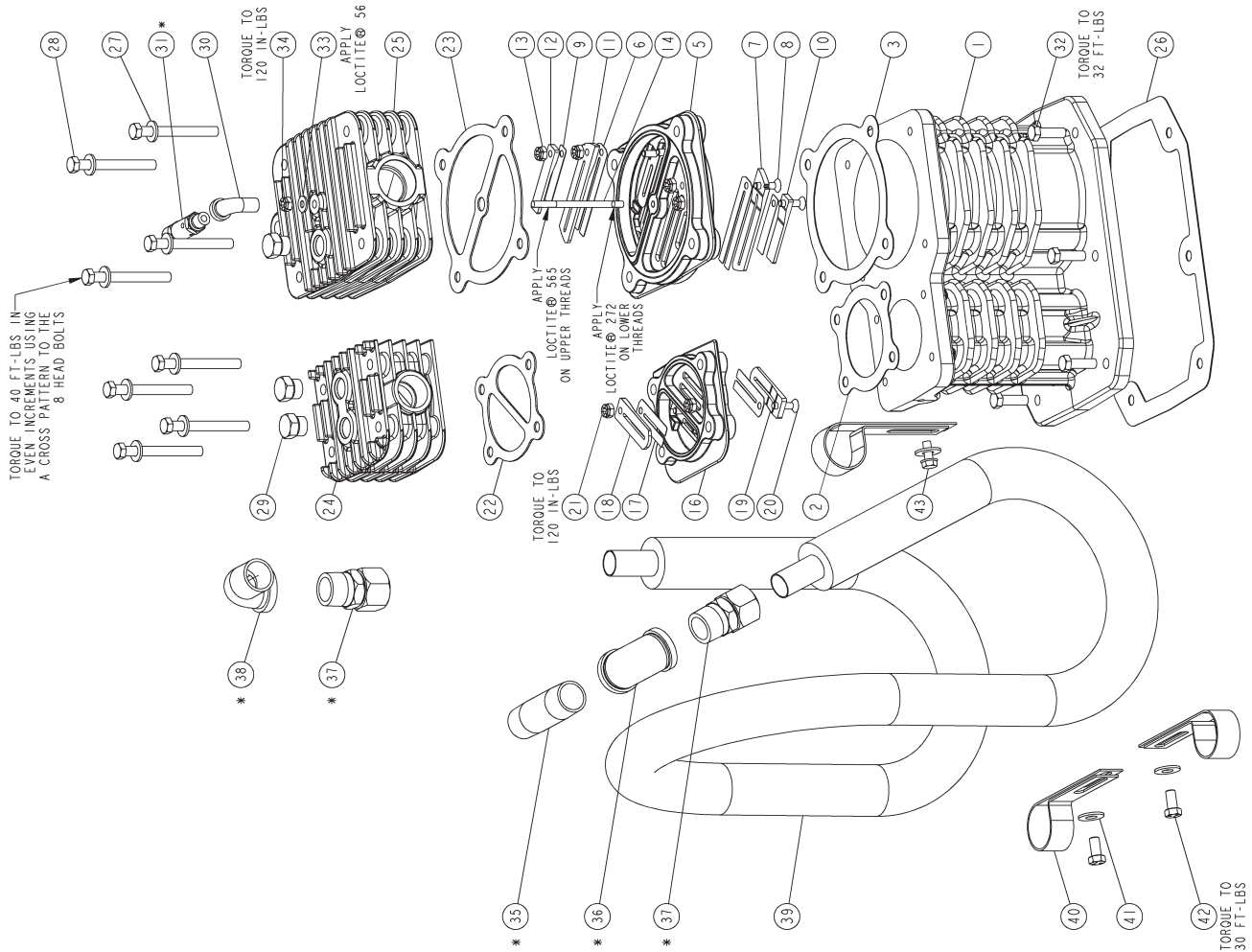

CYLINDER & HEAD GROUP 116178-001

(with head unloaders)

ITEM PART NUMBER	HEAD AND CYLINDER GROUP, UNLOADERS	DESCRIPTION	QTY	BILL OF MATERIALS
1	116172	CYLINDER	1	
2	114599	GASKET, CYLINDER/PLATE, HP	1	
3	114589	GASKET, CYLINDER/PLATE, LP	1	
4	116162X	VALVE PLATE ASSEMBLY, LP	1	
5	116162-001	VALVE PLATE (N.S.S., ORDER V.P. ASSEMBLY)	2	
6	112380	REED VALVE (N.S.S., ORDER V.P. ASSEMBLY)	1	
7	112378-1	BUMPER (N.S.S., ORDER V.P. ASSEMBLY)	1	
8	112728-J12	FLATHEAD SCR, 1/4-20UNC X 1.00, GR 8	4	
9	112359-2	REED VALVE (N.S.S., ORDER V.P. ASSEMBLY)	2	
10	112379	BUMPER (N.S.S., ORDER V.P. ASSEMBLY)	1	
11	112378-3	BUMPER (N.S.S., ORDER V.P. ASSEMBLY)	1	
12	112379-1	BUMPER (N.S.S., ORDER V.P. ASSEMBLY)	1	
13	112373-J02	HEX NUT, 1/4-20 UNC	4	
14	114688	VALVE PLATE STUD	1	
15	116163X	VALVE PLATE ASSEMBLY, HP	1	
16	116163-001	VALVE PLATE (N.S.S., ORDER V.P. ASSEMBLY)	1	
17	112380-001	REED VALVE (N.S.S., ORDER V.P. ASSEMBLY)	2	
18	114645-002	BUMPER (N.S.S., ORDER V.P. ASSEMBLY)	1	
19	114645-003	BUMPER (N.S.S., ORDER V.P. ASSEMBLY)	1	
20	112728-J12	FLATHEAD SCR, 1/4-20UNC X 1.00, GR 8	2	
21	112373-J02	HEX NUT, 1/4-20 UNC	2	
22	111274-002	GASKET, HEAD - VALVE PLATE	1	
23	114586	GASKET, HEAD - VALVE PLATE	1	
24	111115-6	HEAD, HIGH PRESSURE	1	
25	114507	HEAD, LOW PRESSURE	1	
26	114584	GASKET, CYLINDER - CRANKCASE	1	
27	114595ND38	FLAT WASHER, 3/8	8	
28	110983ZL26	HEX SCREW, 3/8-16 UNC X 4.50, GRADE 8	8	
29	112709-006	PLUG, 3/4-16 UNF W/O RING	1	
30	123651-003	PIPE ELBOW, 90° STREET, 1/4 NPT x 1/4 NPT	1	
31	2961-100	PRESSURE RELIEF VALVE	1	
32	115037-L14	SCREW, CAP HEX, SEALANT, GRADE 5	6	
33	114595N025	FLAT WASHER, 1/4	1	
34	112373-J02	HEX NUT, 1/4-20 UNC	1	
35	111650-026	BRASS NIPPLE, 1 NPT X 4.00	1	
36	115101-006	PIPE ELBOW, 1 NPT	1	
37	23358	TUBE FITTING, MALE CONN, 1 X 1 NPT	2	
38	21730-B	PIPE ELBOW, 90° STREET, 1 NPT x 1 NPT	1	
39	114508-001	INTERCOOLER	1	
40	114574	INTERCOOLER CLAMP	3	
41	110428WD38	FLAT WASHER, 3/8	3	
42	123478-L10	HEX SCREW, 3/8-16 UNC X .75, GRADE 5	2	
43	114629-001	FLANGE SCREW, 5/16-18x0.75, GRADE 5	1	
44	114655X2	INTAKE UNLOADER	1	
45	112708-908	O-RING, SILICONE	2	
46	111591X4	INTAKE UNLOADER	1	
47	124351-004	MALE BRANCH TEE, 1/4T X 1/4P	1	
48	2708	TUBE FITTING, 90° ELBOW, 1/4T x 1/4P	1	
49	110515-025	1/4" COPPER TUBE (CUSTOMER TO BEND)	1	
MAINTENANCE PARTS				
114508K002	1	INTERCOOLER REPLACEMENT KIT: INCLUDES INTERCOOLER AND NUT/SLEEVE FITTING		
112708-908	3	O-RING, SILICONE (SEE ITEM 29.43)		
K0T10H	1	HEAD KIT (INCLUDES ITEMS 4, 15 & AIR FILTER ELEMENT)		
110377S125	1	AIR FILTER / SILENCER		
110377E100	1	ELEMENT, AIR FILTER		

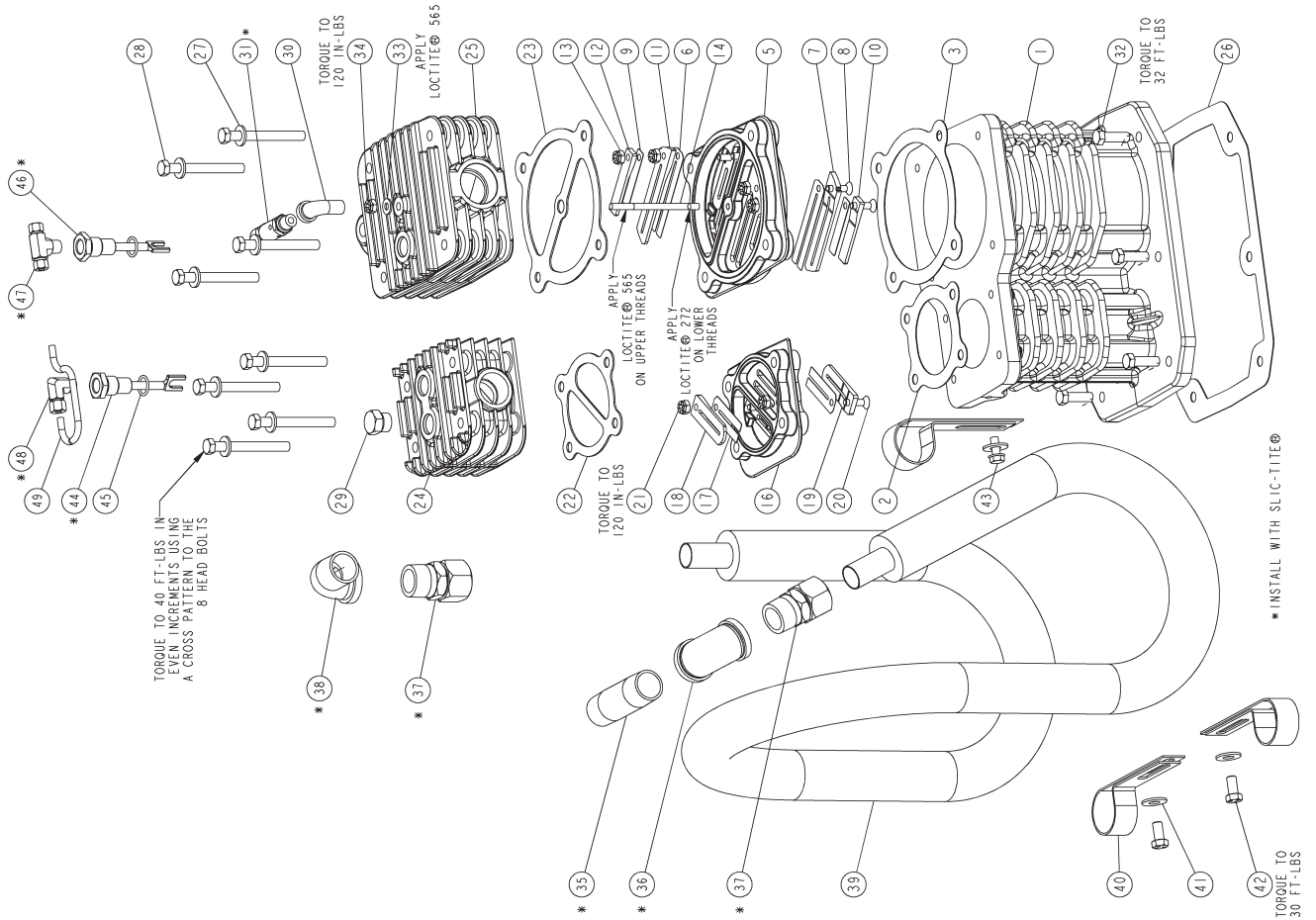

CONNECTING ROD & PISTON GROUP 116176X

(low pressure)

116176X GR, PISTON/ROD, LP BILL OF MATERIALS			
ITEM	PART NUMBER	QTY	DESCRIPTION
1	114662-002	1	CONNECTING ROD ASSEMBLY (N.S.S. ORDER 114662K002)
2	110146	1	PISTON PIN
3	114563	1	PISTON
4	8648	2	RETAINING RING
5	114607	2	OIL RING RAIL
6	114606	1	OIL RING SPACER
7	112301	1	NEEDLE BEARING
8	2025058802	1	PISTON RING, SCRAPER
9	112440-016	2	PISTON RING
MAINTENANCE PARTS			
	116176	1	PISTON RING SET, L.P.
	114662K002	1	CONNECTING ROD KIT (ITEMS 1,7)

N.S.S. = NOT SOLD SEPARATE

RING GAPS TO BE STAGGERED WHEN ASSEMBLED.

PIP MARKS INDICATE TOP SURFACE OF RING.

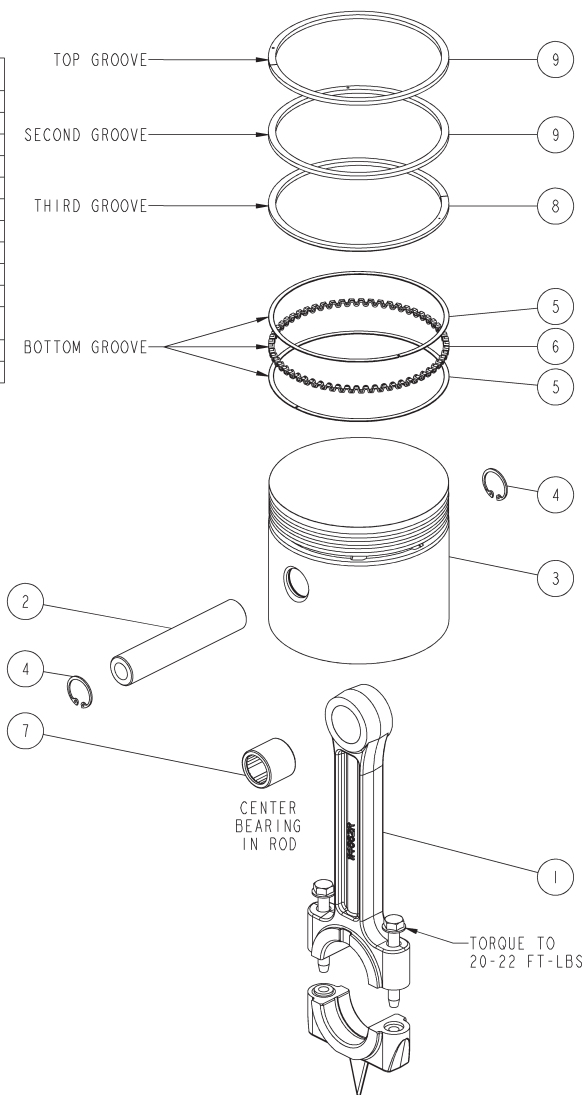

CONNECTING ROD & PISTON GROUP 116177X

(high pressure)

116177X GR, PISTON/ROD,HP BILL OF MATERIALS			
ITEM	PART NUMBER	QTY	DESCRIPTION
1	114662-002	1	CONNECTING ROD ASSEMBLY (N.S.S. ORDER 114662K002)
2	110190-027	1	PISTON PIN
3	116159	1	PISTON
4	8648	2	RETAINING RING
5	112650	2	OIL RING RAIL
6	112651	1	OIL RING SPACER
7	112301	1	NEEDLE BEARING
8	2025058801	1	PISTON RING, SCRAPER
9	112440-017	2	PISTON RING
MAINTENANCE PARTS			
	116177	1	PISTON RING SET, H.P.
	114662K002	1	CONNECTING ROD KIT (ITEMS 1,7)

N.S.S. = NOT SOLD SEPARATE

RING GAPS TO BE STAGGERED WHEN ASSEMBLED.

PIP MARKS INDICATE TOP SURFACE OF RING.

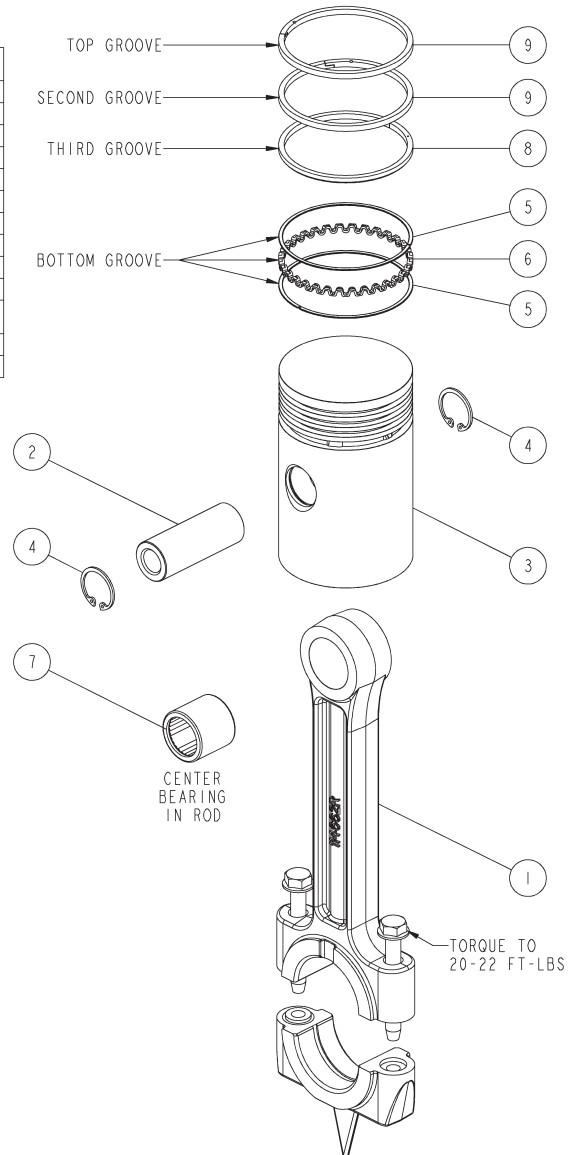

CONTROL PIPING SCHEMATICS

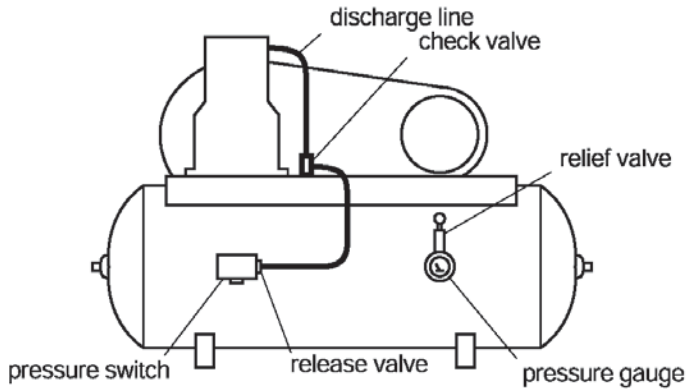

**Control Piping
For Automatic Start/Stop**

(with loadless starting)

**Control Piping
For Continuous Run**

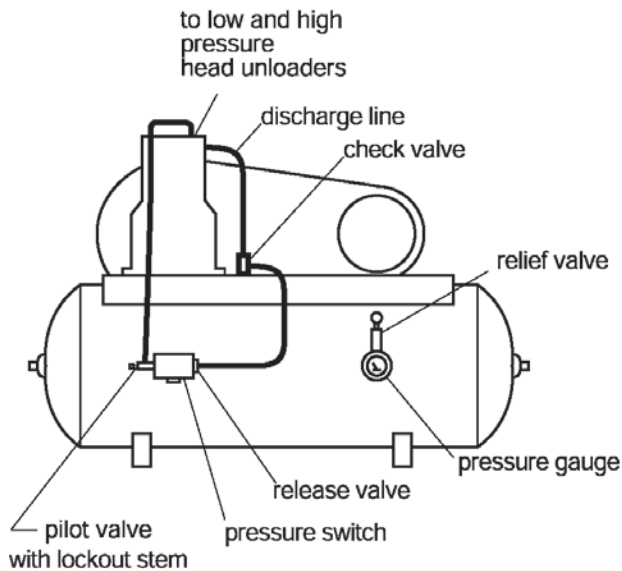
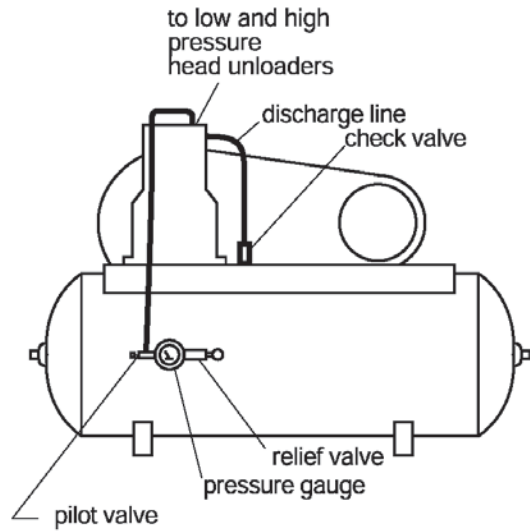

**Control Piping
For Dual Control**

*For Start / Stop operation
the pilot valve is open
(stem screwed out)*

*For Continuous Run operation
the pilot valve is closed
(stem screwed in)*

PILOT VALVES

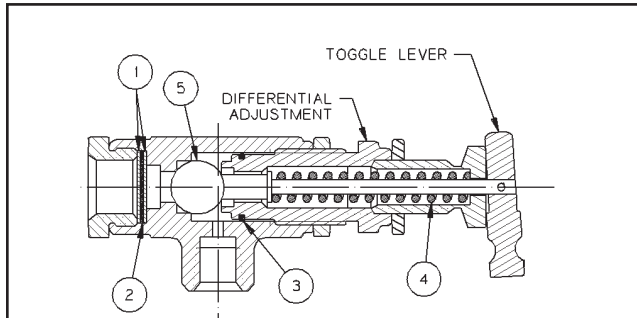

110832 Series Pilot Valve (continuous run operation)
 Add dash # listed below to 110832 (per pressure setting) to obtain correct pilot valve.

Dash #	Load PSI	Unload PSI
-100	90	100
-997	*	30-70 adjustable
-998	*	71-150 adjustable
-999	*	151-175 adjustable

* Customer to set, see differential setting chart. Additional factory preset valves are available upon request.

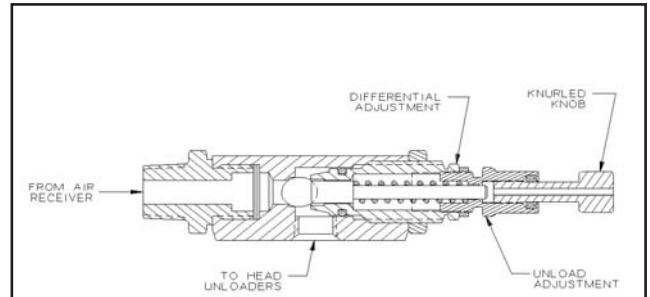

110998 Series Pilot Valve (dual control operation)
 Add dash # listed below to 110998 (per pressure setting) to obtain correct pilot valve.

Dash #	Load PSI	Unload PSI
-115	100	115
-140	125	140
-165	150	165

Pilot Valve Repair Kit 110832-051
 Can be used to repair 110832 series pilot valves only. Customer must specify which spring when ordering repair kit.

Item #	Qty.	Part Number	Description
1	2		screen
2	1		filter
3	1		"o"ring
4	1	see chart below	pilot valve spring
5	1		ball

Differential Setting Chart
 Applies to 110998 series pilot valves only.

Unload (PSI)	Min. Dif. (PSI)	Max. Dif. (PSI)
40	2	5
60	3	10
100	4	20
150	5	30
175	5	45

Spring Part # (item 4)	Unload (PSI)	Min. Dif. (PSI)	Max. Dif. (PSI)
110832-052 (red)	30	2	4
"	40	5	8
"	50	5	8
"	60	5	8
"	70	5	10
110832-053 (yellow)	80	5	10
"	90	5	12
"	100	5	13
"	110	5	15
"	120	5	15
"	130	5	18
"	140	5	18
"	150	5	20
110832-054 (green)	160	5	15
"	170	5	20
"	175	5	23

WARNING !
 Not all pilots are for use with all compressor systems. Make sure that the pilot you order is set within the safe operating limits of your compressor. Failure to heed this warning could result in an explosion.

SUCTION VALVE UNLOADER ASSEMBLIES

Description

The Quincy suction valve unloader assembly consists of unloading assemblies on the suction valves, having a plunger to contact the suction valve reed and an unloader pilot valve (110832 or 110998 series) to automatically regulate the passing of air tank pressure to the unloading arrangement.

Continuous Run Operation

Suction valve unloader assemblies are recommended for use on Quincy compressors where the compressor is to run continuously and a constant pressure is to be maintained. The purpose is to automatically unseat the suction valve of the compressor when the air supply is greater than the demand.

Unloading occurs when air tank pressure is sufficient to overcome pilot valve spring pressure. The check ball is then unseated, allowing air tank pressure to pass to the unloader assemblies. The compressor will run unloaded until the air tank pressure drops to a predetermined level. At this time, the action of the ball is reversed, shutting off air tank pressure to the unloader assemblies and venting the unloader to atmosphere. This allows the compressor to load. The drive, either electric motor or engine, runs continuously and must be started and stopped manually. 110832 series pilot valves feature a toggle lever which can be flipped to provide manual unloading.

Dual Control Operation

Dual control operation is designed to provide a choice between "start/stop" or "continuous run" operation. The 110998 series pilot valve can be set for "start/stop" operation by turning the knurled knob at the end of the pilot valve (refer to illustration for 110998 series pilot valve) clockwise until it stops. Under these circumstances, a pressure switch is required to stop the motor. Failure to use a pressure switch, with the pilot valve locked out, will result in unsafe conditions.

WARNING !

A pressure switch must be incorporated whenever 110998 series pilot valve is employed as part of the control system.

The compressor will operate in the continuous run mode if the knurled knob is turned counterclockwise until it stops.

Installation

The pilot valve is mounted directly into the air tank. Compressors in the field, not equipped with these controls, can be converted. Consult your local Quincy distributor for assistance with conversion procedures.

Service

If a change in pilot valve operation is detected, remove the pilot valve from the air tank and check the screen in the inlet of the pilot valve for obstructions. Clean the screen if necessary.

Adjustment

The unloading pressure is adjustable and is regulated by turning the unload adjustment hex nut (refer to pilot valve illustrations). Turn the hex nut clockwise to increase and counterclockwise to decrease the unloading pressure.

The differential (difference between unloading and loading pressure) is set by turning the differential adjustment hex nut (refer to pilot valve illustrations). Increase the differential pressure by turning the hex nut clockwise - decrease by turning counterclockwise. Make all adjustments in small increments. Tighten the locknuts after adjustment.

DECALS

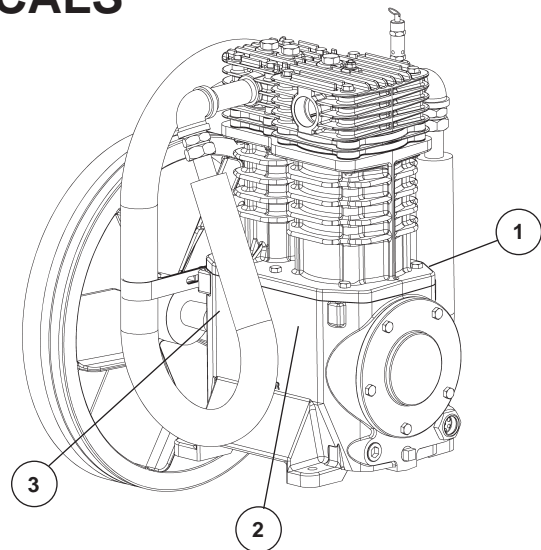

Decals			
Item #	Qty.	Part Number	Description
1	1	110831	serial number & nameplate
2	1	127889-A	decal, CAUTION!, MANUAL
3	1	127889-B	decal, DANGER!, "Air from this...."

TYPICAL UNIT REPAIR PARTS LIST

The parts listed here are for standard QT-10 units and may or may not be applicable to specially built units. Check with your local authorized Quincy distributor for parts that can be used for custom built units. Make sure the components you order are rated within the safe operating limits of your system. If you are doubtful about which components to order, contact your local Quincy distributor.

(QT-10 simplex - horizontal tank - electric motor)

Qty	Part Number	Part Number	Description
	80 gal.		
1	113268-200	113271-200	tank
1	n/a	113281	top plate
1	2713	111136-050	tank drain valve
1	111136-075	111136-100	service valve
1	110514-300	110514-300	pressure gauge
1	110512-005	110512-005	pressure switch, 135-175 PSI
1	110513-200	110513-200	pressure relief valve, 200 PSI (in tank)
1	2961-215	2961-215	pressure relief valve, 215 PSI (in discharge line)
1	116209-100	116209-100	check valve
6 ft.	110515-100	110515-100	! discharge tube (1" copper tube to be formed by customer)
	10 h.p.		
2	<i>110258B082</i>		drive belt
1	<i>110483</i>		motor pulley
1	<i>110484</i>		bushing
1	<i>113242K004</i>	<i>113242K004</i>	belt guard assembly
	200v, 3Ø		
1	<i>40656</i>	230/460v, 3Ø <i>124517-027</i>	10 h.p. motor (ODP)

(QT-10 simplex - vertical tank - electric motor)

Qty	Part Number	Part Number	Description
	120 gal.		
1	114859		tank
1	n/a		top plate
1	2713		tank drain valve
1	111136-075		service valve
1	110514-300		pressure gauge
1	110512-175		pressure switch, 135-175 PSI
1	110513-200		pressure relief valve, 200 PSI (in tank)
1	2961-215		pressure relief valve, 215 PSI (in discharge line)
1	116209-100		check valve
6 ft.	110515-100		! discharge tube (1" copper tube to be formed by customer)
	10 h.p.		
2	<i>110258B082</i>		drive belt
1	<i>110483</i>		motor pulley
1	<i>110484</i>		bushing
1	<i>113242K004</i>		belt guard assembly
	200v, 3Ø		
1	<i>40656</i>	230/460v, 3Ø <i>124517-027</i>	10 h.p. motor (ODP)

Part numbers shown in italics apply to tank mounted units and base mounted units.

! Pre-formed discharge tubes are available. Contact factory with model & tank size information.

TYPICAL UNIT REPAIR PARTS LIST

The parts listed here are for standard QT-10 units and may or may not be applicable to specially built units. Check with your local authorized Quincy distributor for parts that can be used for custom built units. Make sure the components you order are rated within the safe operating limits of your system. If you are doubtful about which components to order, contact your local Quincy distributor.

(QT-10 duplex - horizontal tank - electric motor)

Qty	Part Number	Part Number	Description
	200 gal.	240 gal.	
1	113469-200	112400-200	tank (standard)
1	113468-200	113470-200	tank (pedestal)
1	113281	113282-001	top plate (for pedestal tank)
1	111136-050	111136-050	tank drain valve
1	111136-100	111136-100	service valve
1	110514-300	110514-300	pressure gauge
1	110512-005	110512-005	pressure switch, 135-175 PSI
1	110512-003	110512-003	pressure switch, 125-165 PSI
1	110513-200	110513-200	pressure relief valve, 200 PSI (in tank)
1	2961-215	2961-215	pressure relief valve, 215 PSI (in discharge line)
1	116209-100	116209-100	check valve
12 ft.	110515-100	110515-100	! discharge tube (1" copper tube to be formed by customer)
	10 h.p.		
2	<i>110258B082</i>		drive belt
1	<i>110483</i>		motor pulley
1	<i>110484</i>		bushing
1	<i>113242K004</i>	<i>113242K004</i>	belt guard assembly
	200v, 3Ø	230/460v, 3Ø	
1	<i>40656</i>	<i>124517-027</i>	10 h.p. motor (ODP)

Part numbers shown in italics apply to tank mounted units and base mounted units.

! Pre-formed discharge tubes are available. Contact factory with model & tank size information.

(QT-10 gasoline engine driven)

Qty	Part Number	Part Number	Description
	base unit	tank unit	
1		113716-200	tank, 200 PSI
1	115096	115096	top plate
1		111136-025	tank drain valve
1	111136-075	111136-075	service valve
1	110514-300	110514-300	pressure gauge
1	110513-200	110513-200	pressure relief valve, 200 PSI (in tank)
2	110357B078	110357B078	drive belt
1	115084	115084	engine pulley
1	8924	8924	engine pulley bushing
1	113242-006	113242-006	belt guard assembly
1	113143-004	113143-004	throttle control
1	113720-001	113720	Kohler engine group, 18 h.p. (includes exhaust system& throttle control)
1	2961-215	2961-215	pressure relief valve, 215 PSI (in discharge line)
1	116209-100	116209-100	check valve
2 ft.	110515-100	110515-100	! discharge tube (1" copper tube to be formed by customer)
1	110948-100	110948-100	nut w/ sleeve
1	112316	112316	fuel tank group, 6 gal. (incl. fuel tank & 6 ft. of hose)
1	113708-175	113708-175	pilot, 165-175 PSI

! Pre-formed discharge tubes are available. Contact factory with model & tank size information.

QUINCY COMPRESSOR

STANDARD TERMS AND CONDITIONS

LEGAL EFFECT: Except as expressly otherwise agreed to in writing by an authorized representative of Seller, the following terms and conditions shall apply to and form a part of this order and any additional and/or different terms of Buyer's purchase order or other form of acceptance are rejected in advance and shall not become a part of this order.

The rights of Buyer hereunder shall be neither assignable nor transferable except with the written consent of Seller.

This order may not be canceled or altered except with the written consent of Seller and upon terms which will indemnify Seller against all loss occasioned thereby. All additional costs incurred by Seller due to changes in design or specifications, modification of this order or revision of product must be paid for by Buyer.

In addition to the rights and remedies conferred upon Seller by this order, Seller shall have all rights and remedies conferred at law and in equity and shall not be required to proceed with the performance of this order if Buyer is in default in the performance of such order or of any other contract or order with seller.

TERMS OF PAYMENT: Unless otherwise specified in the order acknowledgment, the terms of payment shall be 1% 15, net forty-five (45) days after shipment. These terms shall apply to partial as well as complete shipments. If any proceeding be initiated by or against Buyer under any bankruptcy or insolvency law, or in the judgment of Seller the financial condition of Buyer, at the time the equipment is ready for shipment, does not justify the terms of payment specified, Seller reserves the right to require full payment in cash prior to making shipment. If such payment is not received within fifteen (15) days after notification of readiness for shipment, Seller may cancel the order as to any unshipped item and require payment of its reasonable cancellation charges.

If Buyer delays shipment, payments based on date of shipment shall become due as of the date when ready for shipment. If Buyer delays completion of manufacture, Seller may elect to require payment according to percentage of completion. Equipment held for Buyer shall be at Buyer's risk and storage charges may be applied at the discretion of Seller.

Accounts past due shall bear interest at the highest rate lawful to contract for but if there is no limit set by law, such interest shall be eighteen percent (18%). Buyer shall pay all cost and expenses, including reasonable attorney's fees, incurred in collecting the same, and no claim, except claims within Seller's warranty of material or workmanship, as stated below, will be recognized unless delivered in writing to Seller within thirty (30) days after date of shipment.

TAXES: All prices exclude present and future sales, use, occupation, license, excise, and other taxes in respect of manufacture, sales or delivery, all of which shall be paid by Buyer unless included in the purchase price at the proper rate or a proper exemption certificate is furnished.

ACCEPTANCE: All offers to purchase, quotations and contracts of sales are subject to final acceptance by an authorized representative at Seller's plant.

DELIVERY: Except as otherwise specified in this quotation, delivery will be F. O. B. point of shipment. In the absence of exact shipping instruction, Seller will use its discretion regarding best means of insured shipment. No liability will be accepted by Seller for so doing. All transportation charges are at Buyer's expense. Time of delivery is an estimate only and is based upon the receipt of all information and necessary approvals. The shipping schedule shall not be construed to limit seller in making commitments for materials or in fabricating articles under this order in accordance with Seller's normal and reasonable production schedules.

Seller shall in no event be liable for delays caused by fires, acts of God, strikes, labor difficulties, acts of governmental or military authorities, delays in transportation or procuring materials, or causes of any kind beyond Seller's control. No provision for liquidated damages for any cause shall apply under this order. Buyer shall accept delivery within thirty (30) days after receipt of notification of readiness for shipment. Claims for shortages will be deemed to have been waived if not made in writing with ten (10) days after the receipt of the material in respect of which any such shortage is claimed. Seller is not responsible for loss or damage in transit after having received "In Good Order" receipt from the carrier. All claims for loss or damage in transit should be made to the carrier.

TITLE & LIEN RIGHTS: The equipment shall remain personal property, regardless of how affixed to any realty or structure. Until the price (including any notes given therefore) of the equipment has been fully paid in cash, Seller shall, in the event of Buyer's default, have the right to repossess such equipment.

PATENT INFRINGEMENT: If properly notified and given an opportunity to do so with friendly assistance, Seller will defend Buyer and the ultimate user of the equipment from any actual or alleged infringement of any published United States patent by the equipment or any part thereof furnished pursuant hereto (other than parts of special design, construction, or manufacture specified by and originating with Buyer), and will pay all damages and costs awarded by competent court in any suit thus defended or of which it may have had notice and opportunity to defend as aforesaid.

STANDARD WARRANTY: Seller warrants that products of its own manufacture will be free from defects in workmanship and materials under normal use and service for the period specified in the product instruction manual. Warranty for service parts will be Ninety (90) days from date of factory shipment. Electric Motors, gasoline and diesel engines, electrical apparatus and all other accessories, components and parts not manufactured by Seller are warranted only to the extent of the original manufacturer's warranty.

Notice of the alleged defect must be given to the Seller, in writing with all identifying details including serial number, type of equipment and date of purchase within thirty (30) days of the discovery of the same during the warranty period.

Seller's sole obligation on this warranty shall be, at its option, to repair or replace or refund the purchase price of any product or part thereof which proves to be defective. If requested by Seller, such product or part thereof must be promptly returned to seller, freight prepaid, for inspection.

Seller warrants repaired or replaced parts of its own manufacture against defects in materials and workmanship under normal use and service for ninety (90) days or for the remainder of the warranty on the product being repaired.

This warranty shall not apply and Seller shall not be responsible or liable for:

- (a) Consequential, collateral or special losses or damages;
- (b) Equipment conditions caused by fair wear and tear, abnormal conditions of use, accident, neglect or misuse of equipment, improper storage or damage resulting during shipping;
- (c) Deviation from operating instructions, specifications or other special terms of sale;
- (d) Labor charges, loss or damage resulting from improper operation, maintenance or repairs made by person(s) other than Seller or Seller's authorized service station.

In no event shall Seller be liable for any claims whether arising from breach of contract or warranty or claims of negligence or negligent manufacture in excess of the purchase price.

THIS WARRANTY IS THE SOLE WARRANTY OF SELLERS AND ANY OTHER WARRANTIES, WHETHER EXPRESS OR IMPLIED IN LAW OR IMPLIED IN FACT, INCLUDING ANY WARRANTIES OF MERCHANTABILITY AND FITNESS FOR PARTICULAR USE ARE HEREBY SPECIFICALLY EXCLUDED.

LIABILITY LIMITATIONS: Under no circumstances shall the Seller have any liability for liquidated damages or for collateral, consequential or special damages or for loss of profits, or for actual losses or for loss of production or progress of construction, whether resulting from delays in delivery or performance, breach of warranty, negligent manufacture or otherwise.

ENVIRONMENTAL AND OSHA REQUIREMENTS: At the time of shipment of the equipment from the factory, Quincy Compressor / Ortman Fluid Power will comply with the various Federal, State and local laws and regulations concerning occupational health and safety and pollution. However, in the installation and operation of the equipment and other matters over which the seller has no control, the Seller assumes no responsibility for compliance with those laws and regulations, whether by the way of indemnity, warranty or otherwise.

June 30, 2003



Reciprocating / Systems: 217.222.7700
E-mail: info@quincycompressor.com
Website: quincycompressor.com

